

HOVERCART

V2021.0.1

EN-----	01
DE-----	09
FR-----	17
ES-----	25
IT-----	33
NL-----	41

HOVERCART MANUAL

Safety Guide

1. This product is based on the self-balancing scooter. And the speed limit is 12KM/H. Please slow down before hearing the alarm sound.
2. For yours and others' safety, please don't either accelerate the kart kit to high speed suddenly or stop suddenly.
3. The safety speed is 10KM/H. When the speed is over 12km/h, the kart kit will be out of control for 0.3-0.5s and user can't apply the brakes immediately.
So please do not ride it at the limit speed, otherwise there may be injury or property loss.
4. The MAX load of this kart kit is 100kg .
5. People less than 12 year-old and over 60 year-old are not allowed to use the kart kit.
6. Please do not ride this kart kit at rainy days or on wet ground.
7. Please do not ride on a slope (over 15°).
8. This device is only for entertainment. Please follow local laws and regulations.
9. Please do not ride it in crowded place.
10. Teenagers are not allowed to ride the kart kit without adult companion.

It will take you a couple of minutes to control this kart kit. Please be careful if you are a starter. If you do not follow the safety guide, it may cause rider or a third party physical injury or property loss. We are responsible for the product's quality. If any physical injury or property loss is caused by wrong operation, we won't be held responsible.

Operation Instructions:

1. Pushing forward both left and right handle makes the Kart Kit go forward.
2. Pulling back both left and right handle makes the Kart Kit go backward.
3. Pull back left handle, the kart kit will turn left.
4. Pull back right handle, the kart kit will turn right.

(Note: Before switching it on, adjust the handles to make sure scooter at horizontal level, to avoid fast moving forward once it turns on. Before switching it off, lift the kart to make scooter in state of no burden, then turn it off).

BOX CONTENT

CONTENTS

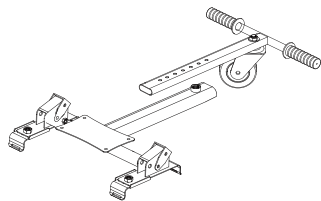

1x Frame (2 parts)



1x Adjustment knob



2x Velcro

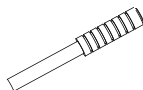

2x Handles



1x Kart seat



A. 4x

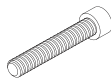

B. 4x



C. 4x



2x



1x

Assembly illustration

1. Mount the handles on the frame on both sides with the nuts A and bolts B.

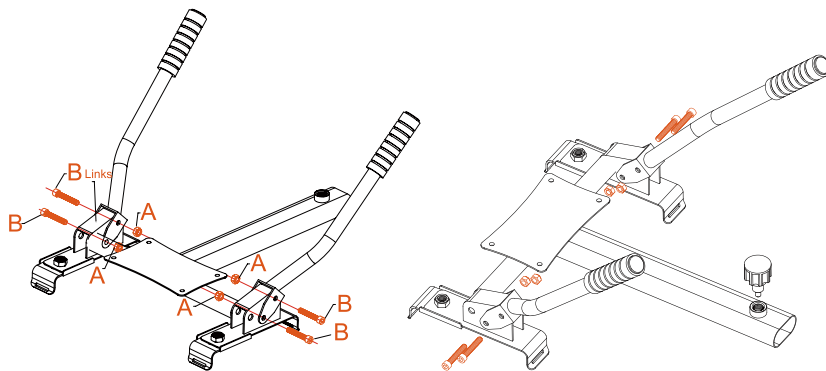

2. Now fasten the adjustment knob into the frame and foot frame

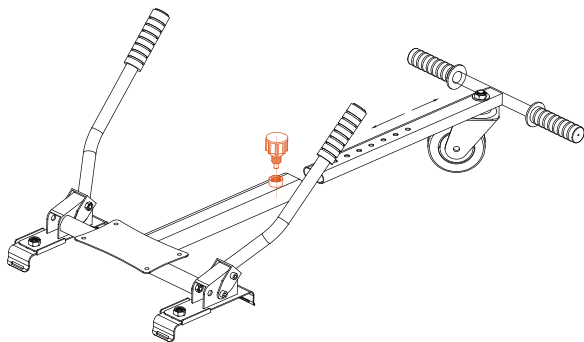

3. Mount the seat on the frame.

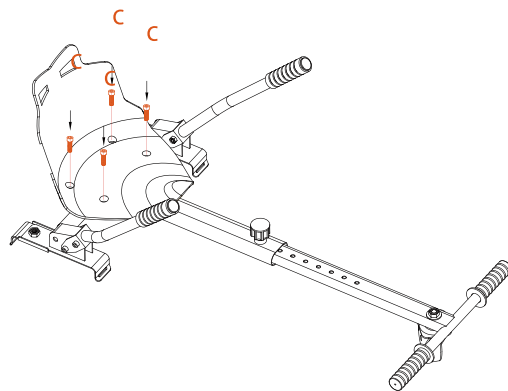

4. Place the Kart kit on your HOVERBOARD.

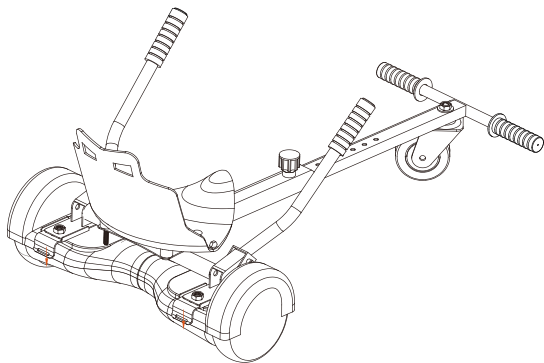

5. Use the sliding metal plate to align the frame to the correct size for your Hoverboard. Fasten the nut tight.

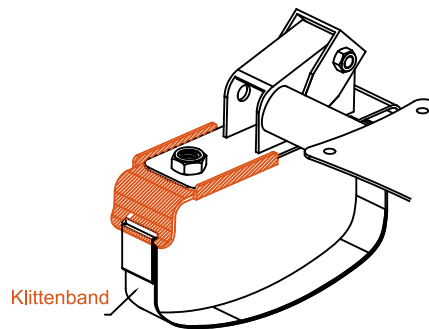

6. Now pull the Velcro tight.

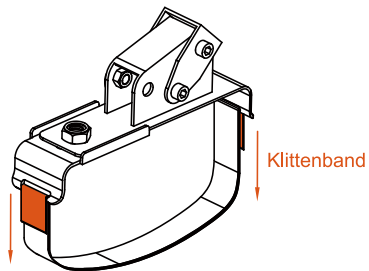

7. Your kart is ready for use.

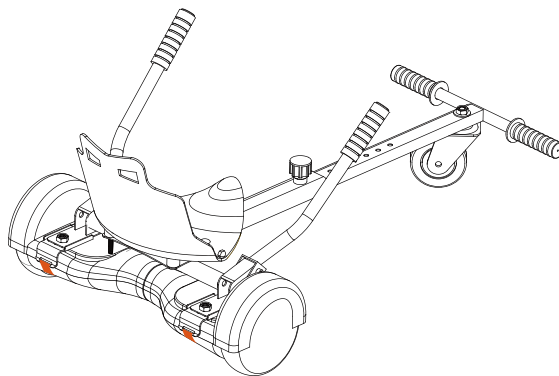

KART-BEDIENUNGSANLEITUNG

Sicherheitshinweise

1. Dieses Produkt basiert auf dem selbstausgleichenden Scooter mit einer Geschwindigkeitsbegrenzung von 12 km/h. Fahren Sie langsamer, wenn Sie den Alarmton hören.
2. Für Ihre eigene Sicherheit und die Sicherheit anderer, beschleunigen Sie den Kart nicht unverhofft und halten Sie nicht plötzlich an.
3. Die Sicherheitsgeschwindigkeit ist 10km/h. Wenn die Geschwindigkeit über 12 km / h liegt, ist das Kart für 0,3 bis 0,5 Sekunden außer Kontrolle und kann nicht sofort gebremst werden. Fahren Sie also nicht mit der Höchstgeschwindigkeit, da es sonst zu Verletzungen oder Sachschäden führen kann.
4. Die zulässige Höchstlast des Karts beträgt 100 kg.

5. Personen jünger als 12 und älter als 60 Jahre dürfen den Kart nicht fahren.
6. Fahren Sie mit dem Kart nicht an Regentagen und auf nassem Untergrund.
7. Fahren Sie nicht an Hängen mit einer Steigung von mehr als 15 Grad.
8. Dieses Gerät dient nur der Unterhaltung. Befolgen Sie die örtlichen Bestimmungen und Gesetze.
9. Fahren Sie nicht an überfüllten Orten.
10. Teenager dürfen den Kart nicht ohne Begleitung eines Erwachsenen fahren.

Es dauert einige Minuten, bis Sie die Kontrolle über diesen Kart gewinnen. Lassen Sie als Anfänger äußerste Vorsicht walten.

Nichtbeachtung der Sicherheitshinweise kann zu Verletzungen des Fahrers oder Dritter, oder zu Sachschäden führen. Wir sind für die Qualität des Produkts verantwortlich. Für Schäden und Verletzungen aufgrund unsachgemäßer Bedienung übernehmen wir jedoch keine Haftung.

Bedienungshinweise:

1. Drücken Sie den linken und rechten Handgriff nach vorn, um vorwärts zu fahren.
2. Ziehen Sie den linken und rechten Handgriff nach hinten, um rückwärts zu fahren.
3. Ziehen Sie den linken Handgriff nach hinten, um eine Linkskurve zu fahren.
4. Ziehen Sie den rechten Handgriff nach hinten, um eine Rechtskurve zu fahren.

(Hinweis: Stellen Sie die Handgriffe vor dem Einschalten ein, damit der Scooter waagrecht steht und um zu vermeiden, dass er beim Einschalten einen Satz nach vorn macht. Heben Sie den Scooter vor dem Ausschalten an, damit er unbelastet ist. Dann schalten Sie ihn aus.)

LIEFERUMFANG

INHALT

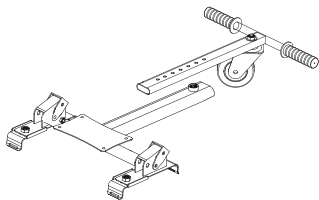

1 x Rahmen (2-teilig)



1 x Einstellknopf



2 x Klettband

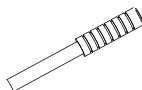

2 x Handgriffe



1 x Sitz



A. 4x

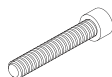

B. 4x



C. 4x



2x

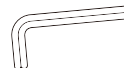

1x

Montageanleitung

1. Montieren Sie die Handgriffe mit den Muttern A und Bolzen B auf beiden Seiten des Rahmens.

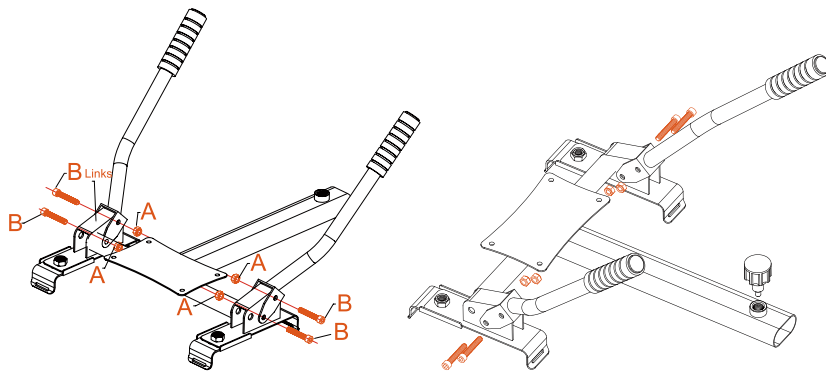

2. Setzen Sie den Einstellknopf im Rahmen und Fußteil ein.

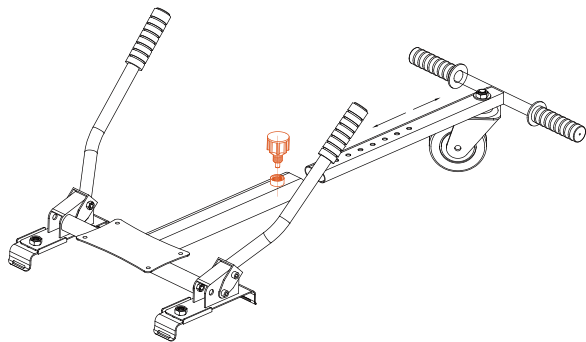

3. Montieren Sie den Sitz auf dem Rahmen.

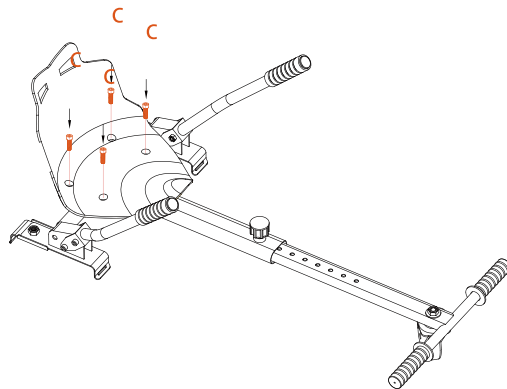

4. Setzen Sie den Kart auf Ihr HOVERBOARD.

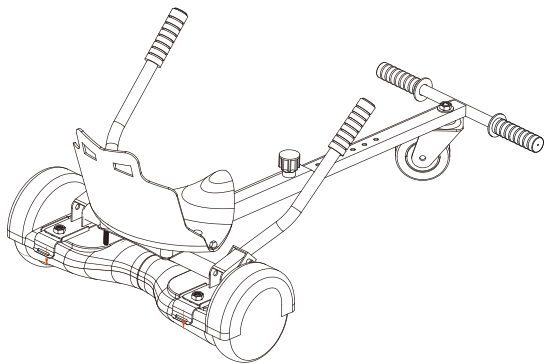

5. Verwenden Sie die verschiebbare Metallplatte zur Ausrichtung des Rahmens mit der korrekten Größe Ihres Hoverboards. Ziehen Sie die Mutter fest an.

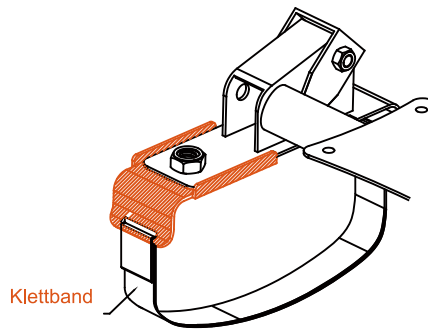

6. Nun ziehen Sie das Klettband fest an.

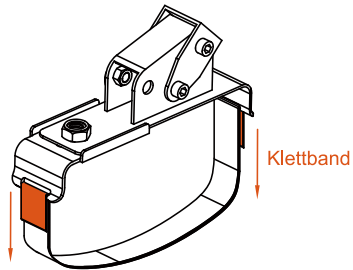

7. Ihr Kart ist betriebsbereit.

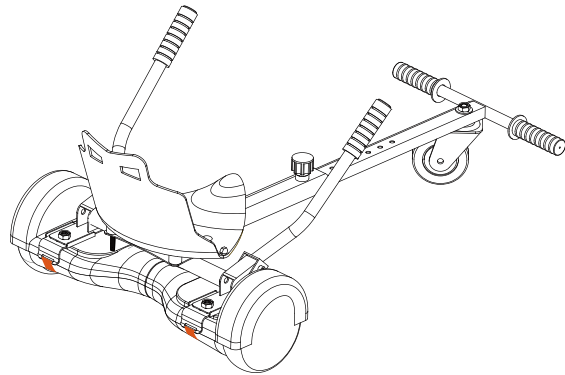

FR

HOVERKART PRO MANUEL

Guide de sécurité

1. Ce produit est basé sur l'équilibrage automatique du hoverboard. Et la limite de vitesse est de 12 km / h. Veuillez ralentir avant d'entendre le son de l'alarme.
2. Pour votre sécurité et celle des autres personnes, évitez d'accélérer brusquement l'appareil ou de s'arrêter brusquement.
3. La vitesse de sécurité est de 10 km / h. Lorsque la vitesse est supérieure à 12 km / h, l'appareil est hors de contrôle pendant 0,3 à 0,5 seconde et l'utilisateur ne peut pas appliquer les freins immédiatement.
Veuillez donc ne pas rouler à la vitesse limite, sinon vous pourriez vous blesser ou perdre des biens.

4. La charge maximale est de 100kg .
5. Les personnes de moins de 12 ans et de plus de 60 ans ne sont pas autorisées à utiliser l'appareil.
6. Ne conduisez pas cet appareil les jours de pluie ou sur un sol humide.
7. Ne roulez pas sur une pente (plus de 15 °).
8. Cet appareil est uniquement destiné au divertissement. Veuillez respecter les lois et réglementations locales.
9. S'il vous plaît ne pas le monter dans un endroit surpeuplé.
10. Les adolescents ne sont pas autorisés à utiliser le kit de karting sans accompagnateur adulte.

Il vous faudra quelques minutes pour contrôler ce produit. S'il vous plaît soyez prudent si vous êtes débutant.

Si vous ne suivez pas le guide de sécurité, il peut en résulter des blessures corporelles, des dommages corporels ou matériels.

Nous sommes responsables de la qualité du produit. Si une blessure ou une perte de biens est causée par une mauvaise opération, nous ne serons pas tenus responsables.

Instruction d'utilisation:

1. Pousser vers l'avant les poignées gauche et droite pour faire avancer le kart.
2. Si vous tirez les poignées gauche et droite vers l'arrière, le kart recule.
3. Tirez la poignée gauche, le kart tourne à gauche.
4. Tirez la poignée droite, le kart tourne à droite..

(Remarque: avant de l'allumer, réglez les poignées pour vous assurer que le scooter est à niveau horizontal, afin d'éviter tout mouvement rapide vers l'avant une fois qu'il est allumé. Avant de l'éteindre, soulevez le kart pour que le scooter ne soit pas surchargé, puis éteignez-le.).

CONTENU DANS LA BOITE

CONTENTS

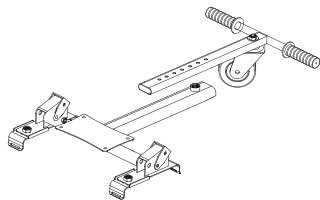

1 x cadre (2 parties)



1 x boutons d'ajustement



2 x Velcro

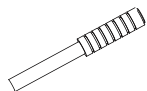

2 x poignéess

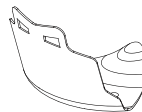

1 x assise pour kart



A. 4x

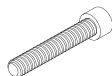

B. 4x



C. 4x



2x

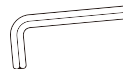

1x

SCHEMA DE L'ASSEMBLAGE

1. Montez les poignées sur le châssis des deux côtés avec les écrous A et les boulons B

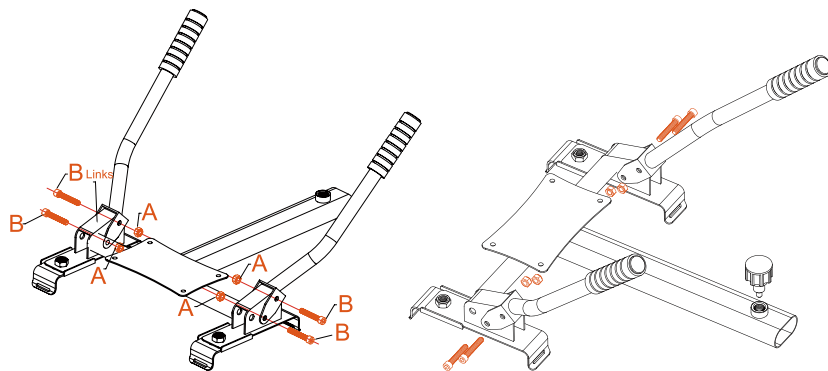

2. Maintenant, fixez le bouton de réglage dans le cadre et le cadre des pieds

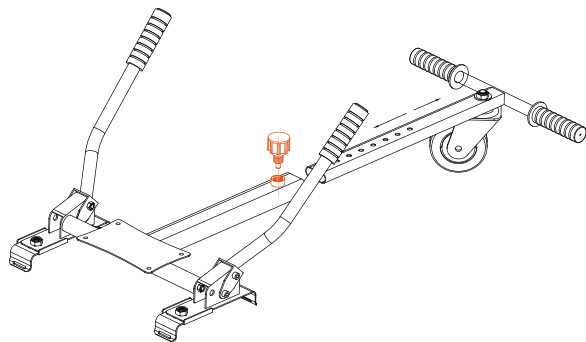

3. Montez la selle sur le cadre.

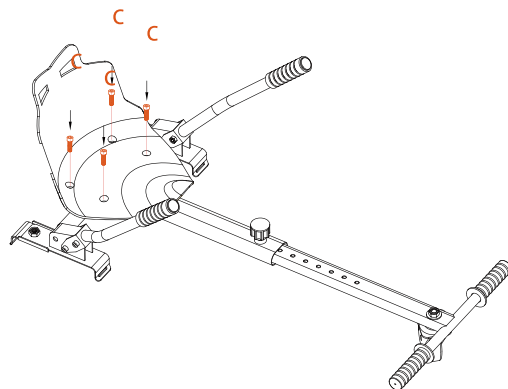

4. Placer le kart sur le hoverboard.

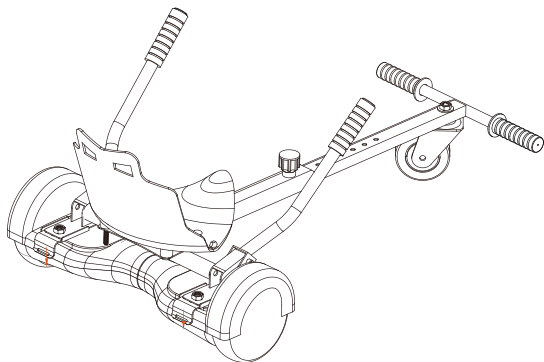

5. Utilisez la plaque métallique coulissante pour aligner le cadre sur votre Hoverboard. Serrez l'écrou.

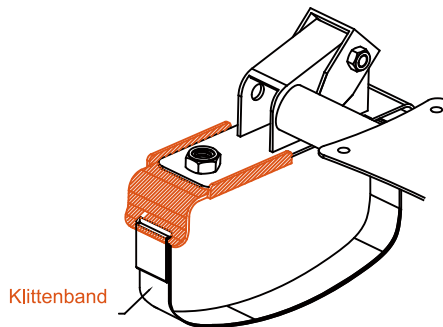

6. Maintenant, tirez le Velcro.

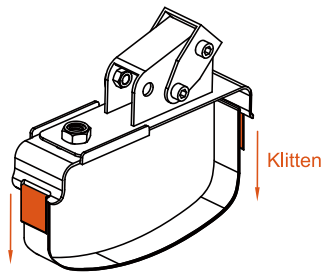

7. Le hoverkart est prêt à être utilisé !.

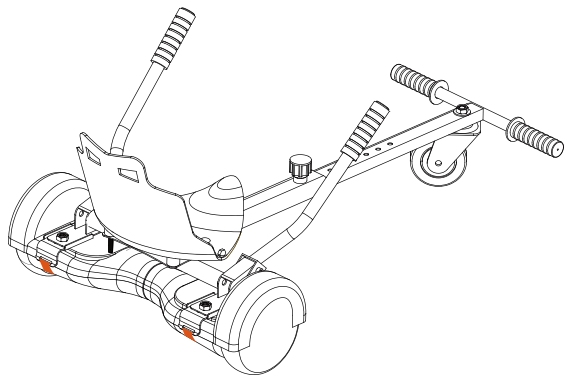

ES

MANUAL DEL HOVERKART

Guía de seguridad

1. Este producto se basa en el hoverboard. Su límite de velocidad es de 12 km/h.
Reduzca la velocidad antes de que suene el sonido de la alarma.
2. Para su seguridad y la de los demás, no detenga ni acelere el hoverkart de forma repentina a una alta velocidad.
3. La velocidad de seguridad es de 10 km/h. Cuando la velocidad supera los 12 km/h, el hoverkart estará fuera de control durante 0,3-0,5 segundos, y el usuario no podrá usar los frenos inmediatamente.
Así que no lo vaya a la velocidad límite, de lo contrario podría haber lesiones o daños a la propiedad.

4. La carga máxima de este hoverkart es de 100 kg.
5. Las personas menores de 12 años y mayores de 60 no están autorizadas a usar el hoverkart.
6. No use este hoverkart en días lluviosos o sobre suelo húmedo.
7. No lo use en una pendiente (más de 15°).
8. Este dispositivo es para el ocio. Obedezca las leyes y regulaciones locales.
9. No lo use en un lugar lleno de gente.
10. Los adolescentes no están autorizados a usar el hoverkart sin la supervisión de un adulto.

Le llevará un par de minutos controlar este hoverkart. Tenga cuidado si es un principiante. Si no sigue la guía de seguridad, esto podría provocar daños físicos o en la propiedad del usuario o de terceros. Somos responsables de la calidad del producto. No nos responsabilizamos de daños físicos o en la propiedad derivados de un mal uso.

Instrucciones de uso:

1. Mover hacia delante las palancas izquierda y derecha hace que hoverkart vaya hacia delante.
2. Tirar hacia atrás de las palancas izquierda y derecha hace que el hoverkart vaya hacia atrás.
3. Tirar hacia atrás de la palanca izquierda hace que el hoverkart gire a la izquierda.
4. Tirar hacia atrás de la palanca derecha hace que el hoverkart gire a la derecha.

(Nota: Antes de encenderlo, ajuste las palancas para asegurarse de que el escúter se encuentra a nivel horizontal, para así evitar que avance rápidamente al encenderlo. Antes de apagarlo, levante el kart para que el escúter se ponga en estado de no carga y a continuación, apáguelo)

CONTENIDO DE LA CAJA

CONTENIDOS

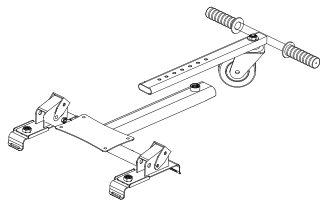

1 cuadro (2 partes)



1 control de ajuste



2 velcros

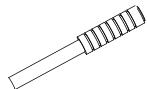

2 palancas

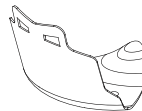

1 asiento de karting



A. 4x

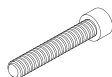

B. 4x



C. 4x



2x



1x

Ilustraciones de montaje

1. Monte las palancas en ambos lados del cuadro con las tuercas A y pernos B.

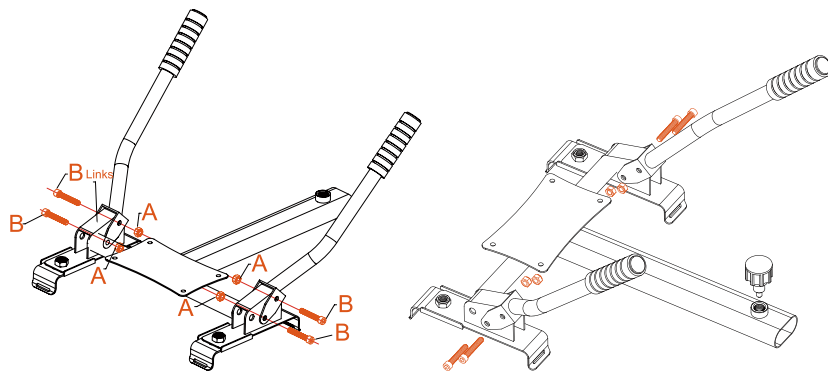

2. Fije el control de ajuste en el cuadro y en el cuadro de los pies

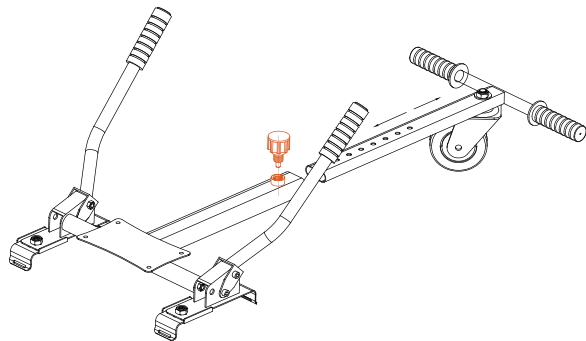

3. Coloque el asiento en el cuadro

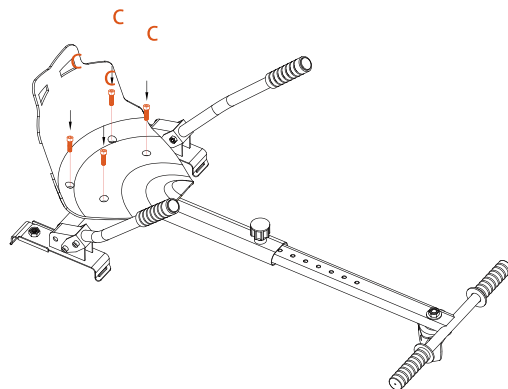

4. Coloque el hoverkart en su HOVERBOARD.

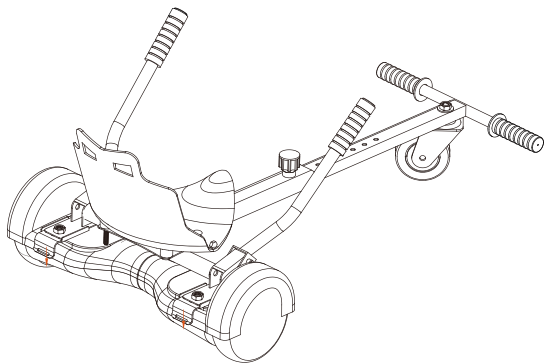

5. Use la placa de metal deslizante para alinear el marco al tamaño correcto de su Hoverboard. Fije la tuerca firmemente.

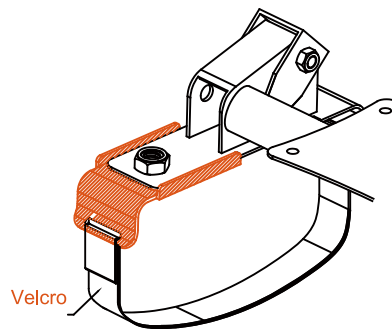

6. Tense el velcro.

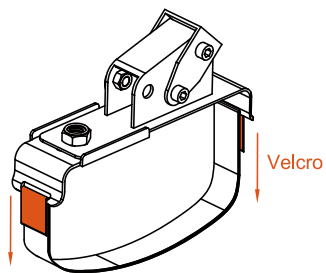

7. Su kart ya está listo para ser usado.

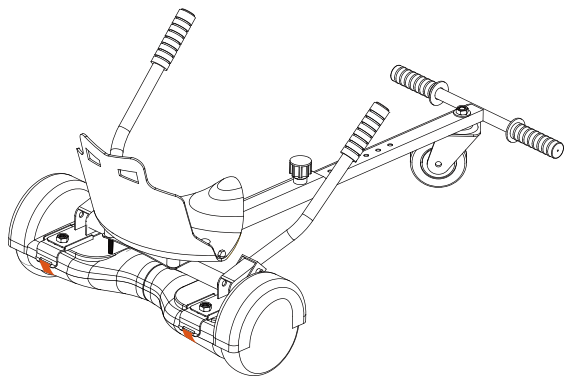

MANUALE DI HOVERCART PRO

Guida della sicurezza

1. Questo prodotto è basato sull'overboard. E il limite max di velocità è 12 km / h. Si prega di rallentare quando senti il suono della sveglia.
 2. Per la sicurezza, non accelerare improvvisamente il kart ad alta velocità o fermarlo improvvisamente.
 3. La velocità di sicurezza è 10 km / h. Quando la velocità supera i 12 km / h, il kart sarà fuori controllo per 0,3-0,5 secondi e l'utente non potrà applicare immediatamente i freni.
- Quindi, per favore non guidarlo alla velocità limite, altrimenti ci possono essere lesioni o perdita di proprietà.

4. Il carico MAX di questo kart è di 100 kg.
5. Le persone con meno di 12 anni e oltre i 60 anni non sono autorizzate a utilizzare il kart.
6. Si prega di non guidare questo kart nei giorni di pioggia o sul terreno bagnato.
7. Si prega di non guidare su un pendio (oltre 15 °).
8. Questo dispositivo è solo per l'intrattenimento. Si prega di seguire le leggi e i regolamenti locali.
9. Si prega di non guidarlo in luogo affollato.
10. I minori non possono guidare il kart senza un accompagnatore adulto.

Ci vorranno un paio di minuti per controllare questo kart. Si prega di fare attenzione se Lei è un principiante.

Se non si segue la guida di sicurezza, ciò potrebbe causare al guidatore o a terzi lesioni fisiche o perdita di proprietà.

Siamo responsabili della qualità del prodotto. Se qualsiasi danno fisico o perdita di proprietà è causato da un'operazione errata, non saremo ritenuti responsabili.

Istruzioni per l'uso:

1. Premendo in avanti sia la maniglia sinistra che quella destra fanno andare avanti il kart.
2. Tirando indietro la maniglia sinistra e destra, il kart va indietro.
3. Tirare indietro la maniglia sinistra, il kart girerà a sinistra.
4. Tirare indietro la maniglia destra, il kart girerà a destra.

(Nota: prima di accenderlo, regola le maniglie per assicurarti che hoverboard sia a livello orizzontale, per evitare che si muova velocemente in avanti una volta acceso. Prima di spegnerlo, solleva il kart per fare in modo che hoverboardr non si carichi, poi spegnilo).

CONTENUTO DELLA SCATOLA

INCLUDE

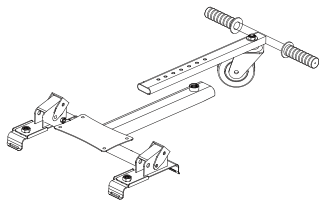

1 x cornice (2 parti)



1 x Manopola di regolazione



2 x velcro

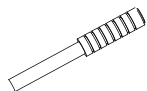

2 x Maniglie

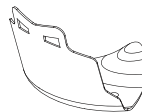

1 x Kart sedie



A. 4x

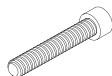

B. 4x



C. 4x



2x



1x

illustrazione

1. Montare le maniglie sul telaio su entrambi i lati con i dadi A e i bulloni B.

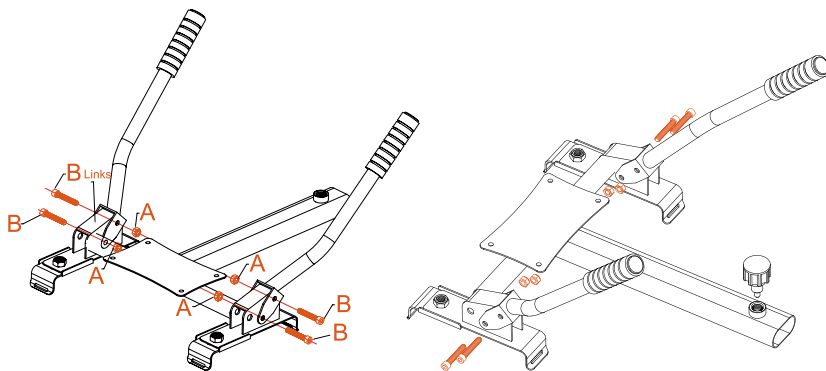

2 . Fissare la manopola di regolazione nel telaio e nella struttura dei piedi

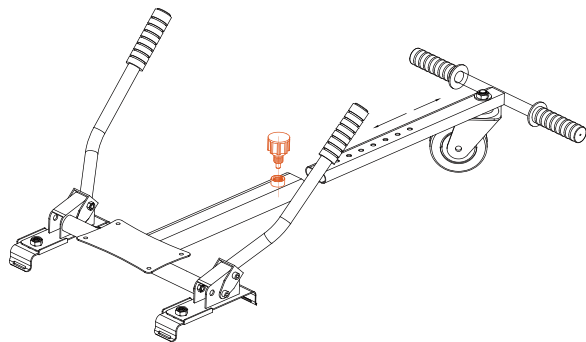

3 . Montare il sedile sul telaio.

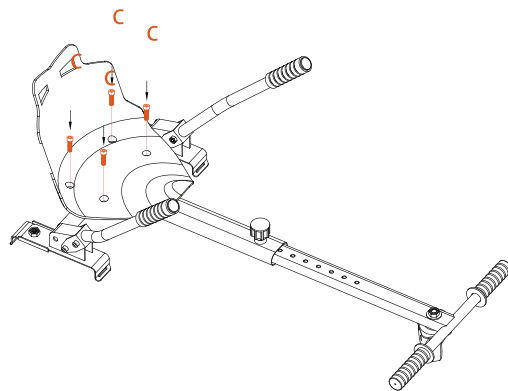

4 . Posiziona il hovercart sul tuo HOVERBOARD.

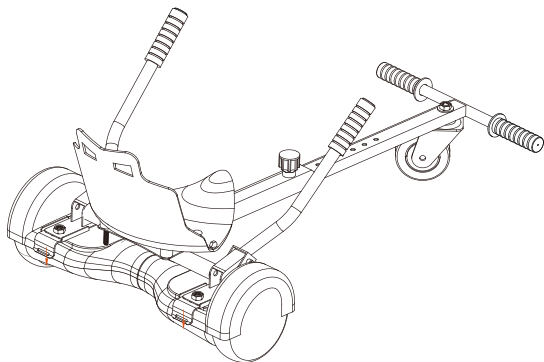

5. Utilizzare la piastra metallica scorrevole per allineare il telaio alla dimensione corretta per il tuo Hoverboard. Fissare il dado stretto.

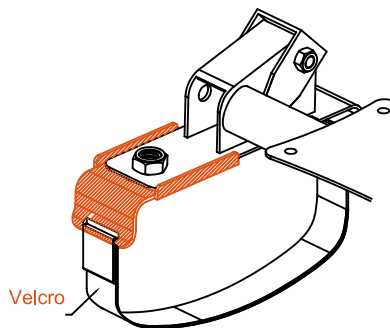

6 . Ora tira il Velcro stretto.

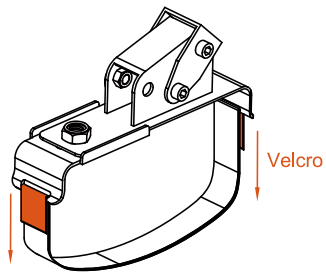

7. Il tuo kart è pronto per l'uso.

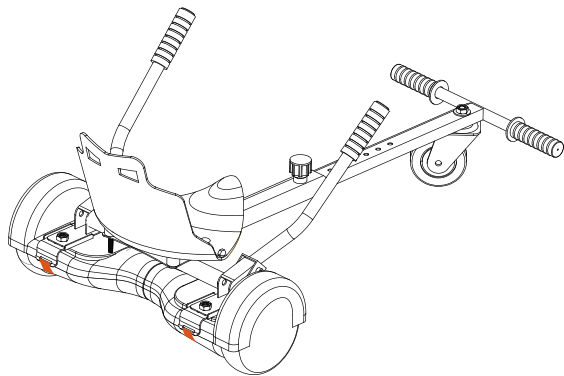

HOVERKART GEBRUIKSAANWIJZING

Veiligheidsinstructies

1. Dit product kan worden gemonteerd op een hoverboard. De snelheidslimiet is 12km/u. Minder vaart voordat het alarmsignaal afgaat.
2. Versnel niet plotseling naar hoge snelheden en stop niet plotseling, voor de veiligheid van u en anderen.
3. De veilige snelheid is 10km/u. Zodra de snelheid over de 12 km/u gaat, zal de kart oncontroleerbaar zijn voor 0,3-0,5 seconden en kan de rem niet onmiddellijk gebruikt worden. Overschrijdt deze snelheid dus niet, om verwonding en schade te voorkomen.

- 4 . De maximale belasting van de kart is 100kg.
5. Personen van minder dan 12 jaar en meer dan 60 jaar oud dienen de kart niet te gebruiken.
6. Rijd niet met de kart op regenachtige dagen of op natte ondergrond.
7. Rijd niet op een helling van meer dan 15°.
8. Dit product is slechts bestemd voor vermaak. Houd u aan de plaatselijke wet- en regelgeving.
9. Rijd er niet mee op drukke plekken.
10. Tieners dienen niet met de kart te rijden zonder ouderlijk toezicht.

Het zal enkele minuten duren om vertrouwd te raken met de kart. Wees voorzichtig als u een beginner bent. Indien de veiligheidsinstructies niet worden opgevolgd, kan dit leiden tot lichamelijk letsel of schade aan bezit van de bestuurder of derden.

Wij zijn verantwoordelijk voor de kwaliteit van het product. Wij zijn niet verantwoordelijk indien er lichamelijk letsel of schade ontstaat door verkeerd gebruik.

Bedieningsinstructies:

- 1.Laat de kart vooruit gaan door zowel de linker als rechter hendel vooruit te drukken.
- 2.Laat de kart achteruit gaan door zowel de linker als rechter hendel achteruit te trekken
- 3.Sla links af door de linker hendel achteruit te trekken
- 4.Sla rechts af door de rechter hendel achteruit te trekken

(Opmerking: Pas voordat u het hoverboard aanzet de hendels zo aan dat deze op horizontaal niveau staan, om te voorkomen dat de kart snel vooruit schiet bij het aanzetten. Til voordat u het hoverboard uitzet de kart op, om ervoor te zorgen dat er geen last rust op het hoverboard wanneer u dit uitzet).

Inhoud van de verpakking

INHOUD

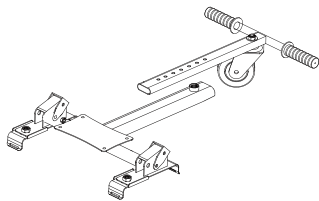

1x Chassis (2 delen)



1 x Verstelbare knop



2x Klittenband

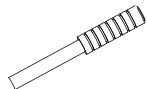

2 x Hendels

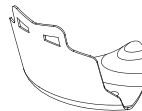

1x Kart zitje



A. 4x

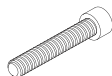

B. 4x



C. 4x



2x



1x

Illustratie voor montering

1. Monteer de hendels op het chassis aan beide zijden met moeren A en bouten B.

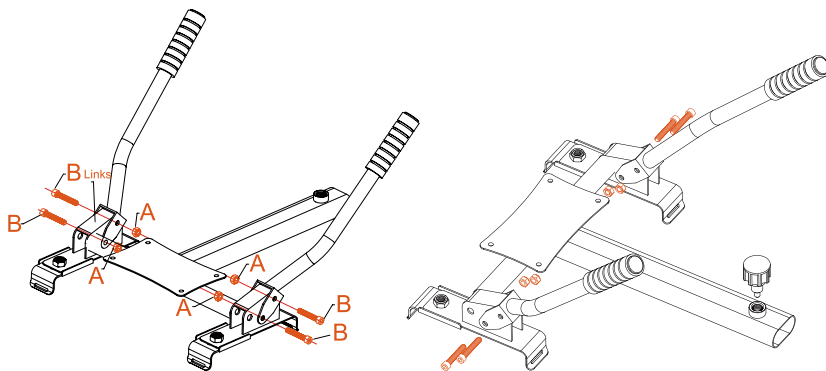

2. Zet de verstelbare knoppen vast op de twee delen van het chassis.

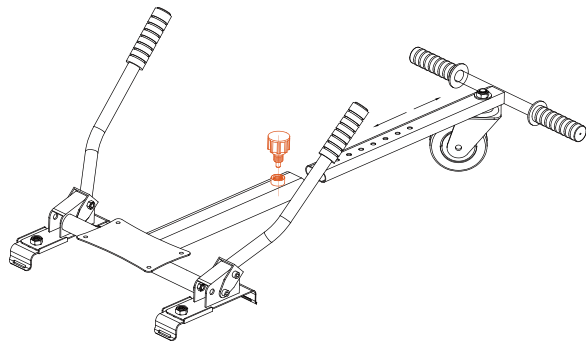

3. Monteer het zitje op het chassis.

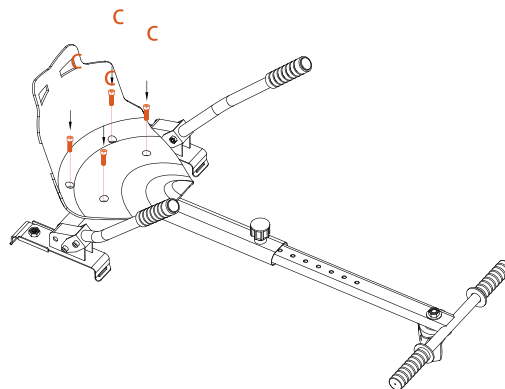

4. Plaats de Hovercart Pro op uw hoverboard.

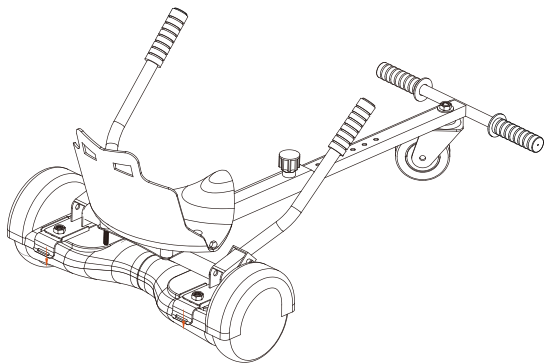

5. Stel met de verschuifbare metaalplaten het chassis in op de omvang van het hoverboard. Draai de moer stevig aan.

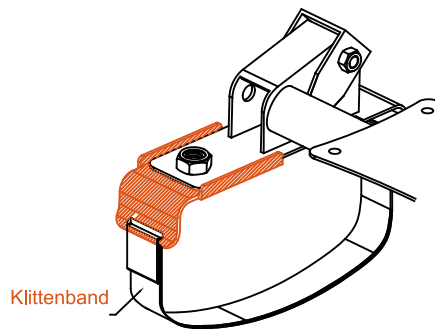

6. Trek het klittenband stevig aan.

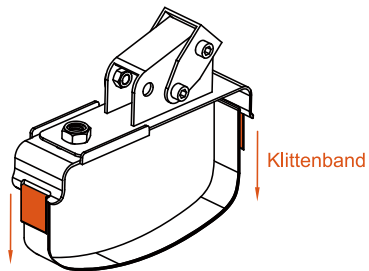

7. De kart is klaar voor gebruik.

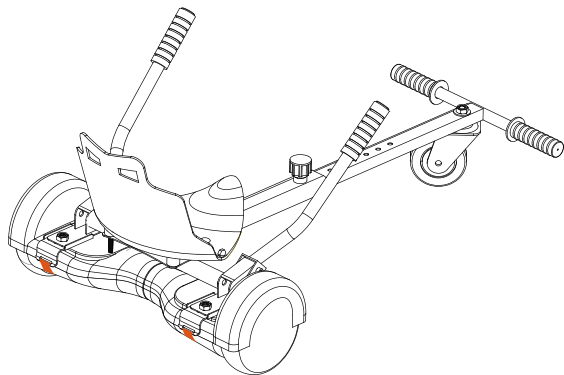



INSTALLATION GUIDE

<https://www.LikeSporting.com>